

Inalca SpA saves over 14,000 cubic meters of water annually with innovative 3D TRASAR™ Cooling Water Technology







INTRODUCTION

Inalca SpA is the leader of meat processing in Italy and is one of the main European beef processors. It produces and sells a complete range of vacuum-packed fresh and frozen meats, products portioned in a protective atmosphere, tinned meats, ready foods, fresh and frozen hamburgers, minced and pre-cooked meats.

Inalca SpA group, consisting of the companies Inalca SpA and Montana Alimentari SpA has 2,500 employees and operates in two areas:

- Beef production
- Charcuterie and snacks

Inalca SpA has a slaughtering capacity of 3,000 head of cattle/day and processes 400,000 tons of meat per year (of which 85,000 tons are hamburgers). The companies' production structure consists of 5 plants in Italy, specialized by processing line, and 9 foreign branches in Europe, Russia and Africa.

CUSTOMER IMPACT	eROI SM	ECONOMIC RESULTS
Over 14,000 m ³ fresh water saved thanks to the implementation of the 3D TRASAR Technology	 WATER	Savings of €10,250/year
2,413 GJ gas saved for increased cycles of concentration in the boilers	 ENERGY	€41,000/year savings in gas consumption
55,000 Kg of commodity chemicals saved thanks to the pre-treatment plant enhancements	 ASSETS	Savings in commodity chemicals amounting to €16,500/year
CO ₂ reduction of 120 tons/year	 AIR	Minor
Zero accidents during the cooperation time with Nalco Water meeting the customer's KBD for safety	 SAFETY	

eROI is our exponential value: the combined outcomes of improved performance, operational efficiency and sustainable impact delivered through our services and programs.

The entire sector consists of 9 highly automated production plants, specialized by product type: five dedicated to beef production and four producing charcuterie and snacks.

Montana Alimentari Spa is among the top Italian companies in the production, sales and distribution of charcuterie and snacks, with over 230 products offered. Owner of the historic brand "Montana" and of the brand "IBIS", the company has a production structure of 4 plants, specialized by product type and located in the production areas distinguished by the DOP (PDO - Protected Designation of Origin) and IGP (PGI -Protected Geographical Indication) marks. It is also one of the main operators in the market of tinned meats and pre-sliced charcuterie in Italy.

In various degrees Nalco Water is a partner of Inalca's in all Italian plants.

Nalco Water's partnership with Inalca in Rieti for water treatment in boiler, cooling and process sections has continued to grow since 2011 with innovation being one of the main components of the partnership (3D TRASAR Cooling Water Technology was already implemented on the retorts cooling system, on both legs of the hydrostatic sterilizer, hot and cold and on the evaporative condensers cooling system).

BACKGROUND

Inalca Spa's corporate responsibilities take the form of 10 basic fundamentals which involve the whole company. They include:

- All activities, are adequately supervised, managed and documented in terms of quality, environmental protection and safety in the workplace.
- The highest level of food safety is considered the first requirement.
- Production activities are closely controlled in relation to contractual obligations undertaken with clients.
- The environmental impact, either real or hypothetical is carefully identified.
- Safety and prevention in the workplace is supervised, managed and shared, regarding both workers and contracted third party companies.
- Effects on the company's activities due to the application of ethical codes of conduct drafted or received by Inalca Spa are supervised and managed, and more particularly employees are provided with a safe and healthy working environment.

For INALCA, sustainable growth constitutes a complex of knowledge, activities and industrial processes whose essential aim is to keep constant control over the

consumption and environmental impact deriving from its production processes and to define the actions required to reduce these in a documented and measurable way.

The main policies through which the company pursues sustainable growth are:

- Energy efficiency and own energy production (cogeneration).
- The use of renewable energy sources and recovery of waste and by-products (biogas production).
- Improvement of the product life cycle (LCA - Life Cycle Assessment).
- Dissemination of good farming practices for sustainability, throughout the agricultural world.

CUSTOMER'S GOALS

Inalca Spa Group has equipped its production plants with the most modern technology available in the environmental field, particularly in the water, energy and waste sectors.

WATER

Inalca Spa's resources are most concentrated in the area of water consumption, water being the most precious resource for its production cycle. In particular, Inalca Spa has optimised the complete cycle of waste water purification and recovery in its own production plants using biological systems. The water cycle efficiency indicators are carefully controlled in the environmental management system.

ENERGY

Inalca Spa has developed the sensitivity and experience to effectively reduce and recover energy in its own production plants, which are the largest in Europe within their sphere of activity.

In terms of energy recovery, Inalca Spa's efforts are mainly aimed at the use of advanced cogeneration and waste-to-energy systems.

In line with the new legislative provisions which stimulate energy efficiency initiatives, Inalca Spa - via its own controlled company SARA S.r.l. - has started up energy efficiency projects certified by the energy distribution companies (White Certificates or Energy Efficiency Titles, Italian acronym TEE).

Inalca Spa is also actively involved in further innovative projects for the recovery and transformation to energy of its own biomass and the reduction of greenhouse gas emissions.

WASTE

Where possible, Inalca Spa promotes reduction of waste production at source, and its re-use as far as possible. To this end, Inalca Spa promotes - through its own controlled company SARA S.r.l. - the recovery of certain types of waste by composting (the controlled transformation of its organic waste into products for agriculture).



Figure 1: The Rieti Plant

The site specialises in the production of canned meats and combat food rations. The raw materials used by the plant consist of bovine meat, and at full capacity production the plant can process up to 40,000 tons of meat per year.

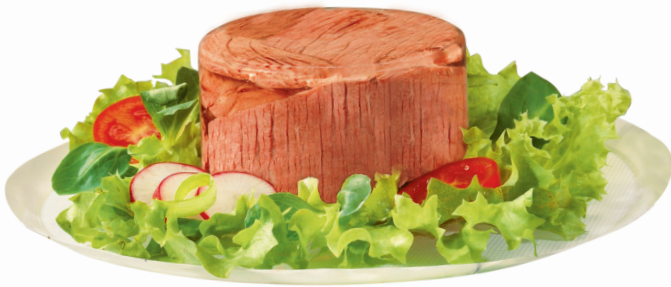

The plant is equipped with a heating plant consisting of 3 boilers fuelled by methane gas, guaranteeing generation of the steam necessary for production. The availability of electrical energy is guaranteed both by the public medium tension network and by the plant's own production from a cogeneration system using methane gas, which also allows the plant to produce steam and hot water using the heat present in the exhaust fumes.

Nalco was cooperating with the operations of the Rieti plant. For this plant, the key business drivers are:

- Safety first
- Food quality
- Monitor and reduce site water & energy consumption
- Monitor and reduce site TCO (maintenance and labour costs)
- Improve site process operations



Nalco Water 3D TRASAR unit in the retorts cooling system



Nalco Water 3D TRASAR units in hot and cold legs of STORK hydrostatic sterilizer

Despite years of general economic crisis, the site production levels were growing. In addition the customer was increasing its commitment and effort to TCO reduction and water, energy and waste reduction.

The Nalco Water team was able to continue to meet the customer needs in terms of innovative programs looking at value delivery and helping to meet the site key business drivers (KBDs).

SOLUTIONS

Nalco Water and Inalca Rieti agreed upon on list of projects to pursue:

- Safety: ZERO accidents
- Water preparation: DEMI plant replacement with a Nalco RO plant to reduce chemicals and TCO
- Nalco Water 3D TRASAR Boiler Technology implementation (three units) to improve boiler assets reliability and save water & energy
- Water reuse: Vacuum pumps cooling water reuse as MU for Evaporative Condensers (EC's)
- Water reuse/recycle: Hydrostatic sterilizer and retorts sterilizers cooling water reuse

RESULTS

Below is the status and outcome of the selected projects as discussed and agreed with the customer during the last business review:

Project	Results				Status
	Total saving-€/y	eROI	Payback	Water-mc/y	
SAFETY	ZERO onsite Accidents				Closed and relaunched
RO plant installation	31,740 (commodities)				Closed
3D TRASAR Boiler Technology implementation	41,915	101%	12 months	363	Closed
Water reuse for EC's MU	10,250			14,000	Closed
Sterilizers cooling water reuse	Planned for next year				Third party engineering in progress



The new Nalco Water RO plant



The new 3D TRASAR Boiler Technology units

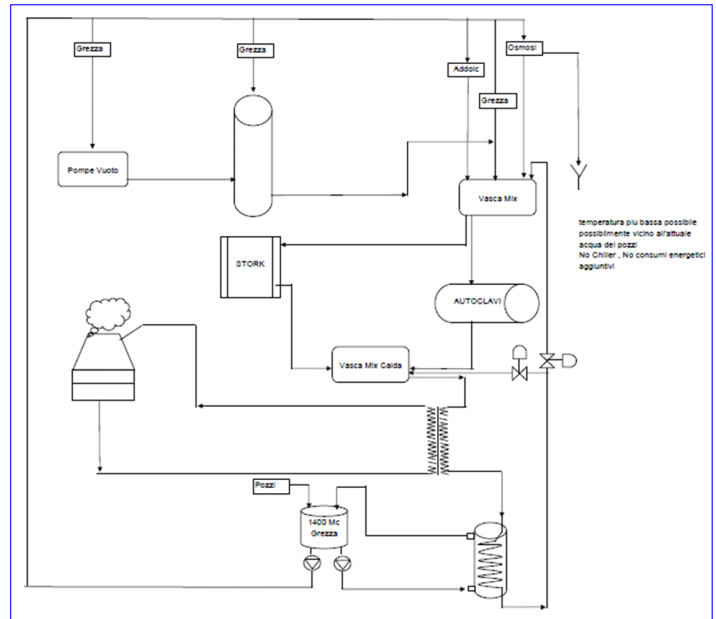

The basic layout for sterilizers cooling water recovery

CONCLUSIONS

The Inalca Group and Nalco Water have today a consolidated history of partnership and mutual credibility based on technical & financial results and value delivery that met both the companies' mission and KBD's.

Safety, Water, Energy and Sustainability projects goals were achieved at the Rieti plant and new common projects are targeted for the coming years.

Nalco Water is committed to promote and deliver to Inalca sites the best available technologies and the most Innovative Programs coming from his research efforts (Innovation).

Those projects, as in the past, will always include new products, new automation and new services that can help reduce cost, environmental footprint, and the impact vs. local communities.

Nalco Water is committed to upholding the business code of conduct of both companies

NALCO Water, an Ecolab Company

North America: 1601 West Diehl Road • Naperville, Illinois 60563 • USA

Europe: Richtstrasse 7 • 8304 Wallisellen • Switzerland

Asia Pacific: 2 International Business Park • #02-20 The Strategy Tower 2 • Singapore 609930

Latin America: Av. das Nações Unidas 17.891 • 6° andar • São Paulo • SP • Brazil • CEP 04795-100

nalco.ecolab.com

3D TRASAR, NALCO Water and the logo are Trademarks of Ecolab USA Inc.
©2016 Ecolab USA Inc. All Rights Reserved 8-16 CH-1951E

NALCO Water
An Ecolab Company